

**Exercise: Quantum Computing**  
**Problem set 10 (to be discussed in week of July 8st, 2019)**

---

**Problem 1 The Shor code and single qubit errors**

We have discussed the 9-qubit Shor code in the lecture that allows for the correction of a general one-qubit error. The code can be implemented using the following circuit:

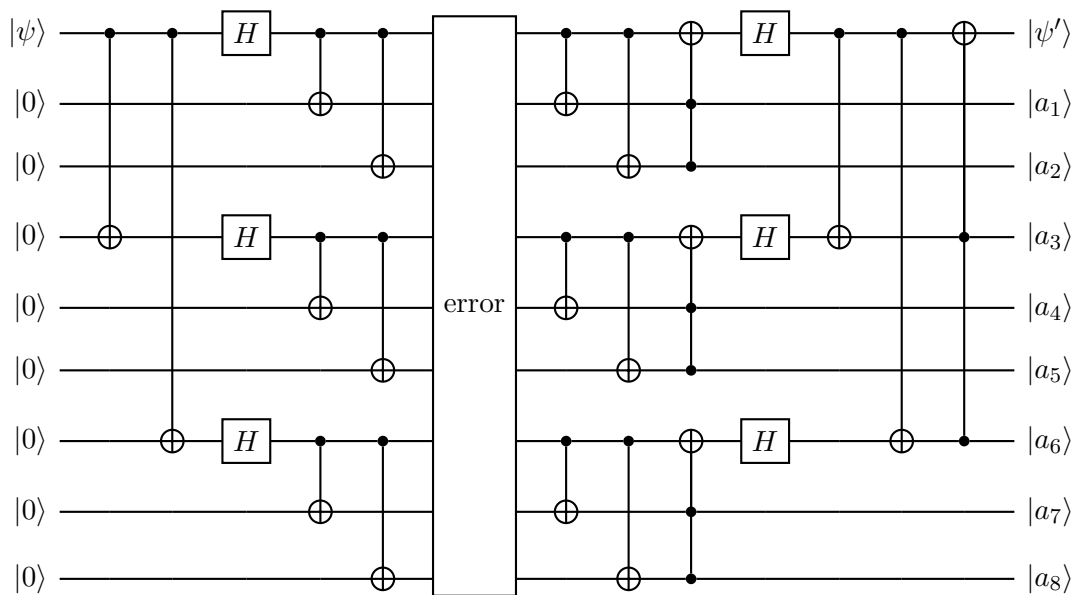

At the end of the circuit, we perform measurements on all ancilla qubits ( $|a_1\rangle, \dots, |a_8\rangle$ ) and if the measured bits are 1, we apply a NOT gate on the corresponding qubits to reset all ancilla qubits to  $|0\rangle$ .

Explicitly construct the final state of the circuit with

$$|\psi\rangle = c_0 |0\rangle + c_1 |1\rangle \tag{1}$$

after the ancilla reset, discussing all possible cases of ancilla measurements. Do this for the following error gates:

- a) a single bit flip on the least-significant (top) qubit,
- b) a single sign flip on the least-significant qubit,
- c) a combined bit and sign flip on the least-significant qubit

with bit flip gate (X) and sign flip gate (Z).

## Problem 2 Failure rate of the Shor code (optional)

Implement the Shor code circuit of the previous exercise in the simulator (sqc). The error gate shall be the product of an error gate for each individual qubit. For each individual qubit, the gate should contain a factor of  $X$  with probability  $p_{\text{bit flip}}$  and of  $Z$  with probability  $p_{\text{phase flip}}$  such that the gate shall be either  $\mathbb{1}$ ,  $X$ ,  $Z$ , or  $XZ$ .

For the case of  $p_{\text{bit flip}} = p_{\text{phase flip}} = p$ , run the circuit 1000 times and count how many times the circuit succeeded in correcting the error. Note that an overall phase is not detectable. Perform this exercise for all

$$p \in [0.005, 0.01, 0.015, 0.02, 0.03, 0.05, 0.1, 0.15]. \quad (2)$$

How does the result compare to the expected failure rate of a single physical qubit without error correction?